

MATHEMATICS

9709/42

Paper 4 Mechanics 1 (M1)

October/November 2014

1 hour 15 minutes

Additional Materials: Answer Booklet/Paper
Graph Paper
List of Formulae (MF9)



READ THESE INSTRUCTIONS FIRST

If you have been given an Answer Booklet, follow the instructions on the front cover of the Booklet.

Write your Centre number, candidate number and name on all the work you hand in.

Write in dark blue or black pen.

You may use an HB pencil for any diagrams or graphs.

Do not use staples, paper clips, glue or correction fluid.

DO **NOT** WRITE IN ANY BARCODES.

Answer **all** the questions.

Give non-exact numerical answers correct to 3 significant figures, or 1 decimal place in the case of angles in degrees, unless a different level of accuracy is specified in the question.

Where a numerical value for the acceleration due to gravity is needed, use 10 m s^{-2} .

The use of an electronic calculator is expected, where appropriate.

You are reminded of the need for clear presentation in your answers.

At the end of the examination, fasten all your work securely together.

The number of marks is given in brackets [] at the end of each question or part question.

The total number of marks for this paper is 50.

Questions carrying smaller numbers of marks are printed earlier in the paper, and questions carrying larger numbers of marks later in the paper.

This document consists of 4 printed pages.

- 1 A particle P is projected vertically upwards with speed 11 m s^{-1} from a point on horizontal ground. At the same instant a particle Q is released from rest at a point $h \text{ m}$ above the ground. P and Q hit the ground at the same instant, when Q has speed $V \text{ m s}^{-1}$.

(i) Find the time after projection at which P hits the ground. [2]

(ii) Hence find the values of h and V . [2]

2

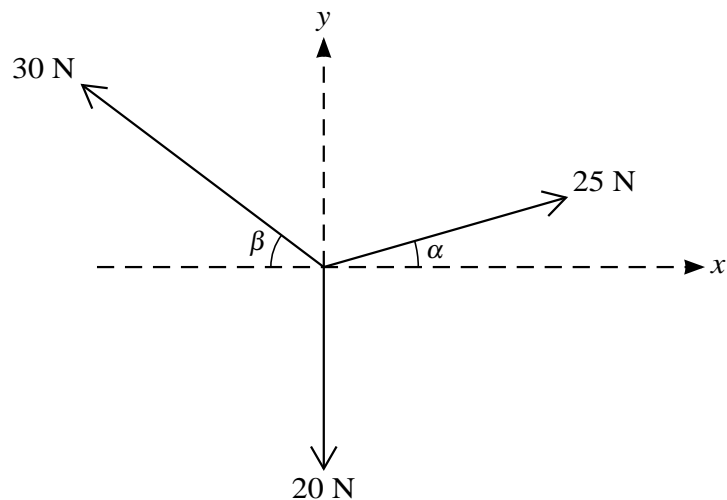

Three coplanar forces act at a point. The magnitudes of the forces are 20 N , 25 N and 30 N , and the directions in which the forces act are as shown in the diagram, where $\sin \alpha = 0.28$ and $\cos \alpha = 0.96$, and $\sin \beta = 0.6$ and $\cos \beta = 0.8$.

(i) Show that the resultant of the three forces has a zero component in the x -direction. [2]

(ii) Find the magnitude and direction of the resultant of the three forces. [2]

(iii) The force of magnitude 20 N is replaced by another force. The effect is that the resultant force is unchanged in magnitude but reversed in direction. State the magnitude and direction of the replacement force. [1]

- 3 A train of mass $200\,000 \text{ kg}$ moves on a horizontal straight track. It passes through a point A with speed 28 m s^{-1} and later it passes through a point B . The power of the train's engine at B is 1.2 times the power of the train's engine at A . The driving force of the train's engine at B is 0.96 times the driving force of the train's engine at A .

(i) Show that the speed of the train at B is 35 m s^{-1} . [2]

(ii) For the motion from A to B , find the work done by the train's engine given that the work done against the resistance to the train's motion is $2.3 \times 10^6 \text{ J}$. [3]

4

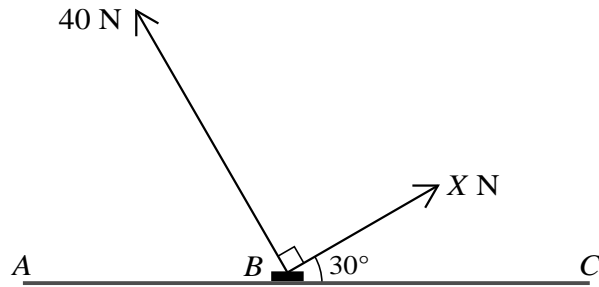

Forces of magnitude X N and 40 N act on a block B of mass 15 kg, which is in equilibrium in contact with a horizontal surface between points A and C on the surface. The forces act in the same vertical plane and in the directions shown in the diagram.

- (i) Given that the surface is smooth, find the value of X . [2]
- (ii) It is given instead that the surface is rough and that the block is in limiting equilibrium. The frictional force acting on the block has magnitude 10 N in the direction towards A . Find the coefficient of friction between the block and the surface. [5]

5

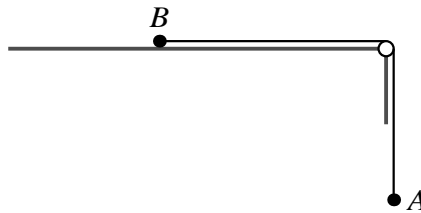

Particles A and B , each of mass 0.3 kg, are connected by a light inextensible string. The string passes over a small smooth pulley fixed at the edge of a rough horizontal surface. Particle A hangs freely and particle B is held at rest in contact with the surface (see diagram). The coefficient of friction between B and the surface is 0.7. Particle B is released and moves on the surface without reaching the pulley.

- (i) Find, for the first 0.9 m of B 's motion,
- (a) the work done against the frictional force acting on B , [2]
- (b) the loss of potential energy of the system, [1]
- (c) the gain in kinetic energy of the system. [2]

At the instant when B has moved 0.9 m the string breaks. A is at a height of 0.54 m above a horizontal floor at this instant.

- (ii) Find the speed with which A reaches the floor. [3]

[Questions 6 and 7 are printed on the next page.]

- 6 ABC is a line of greatest slope of a plane inclined at angle α to the horizontal, where $\sin \alpha = 0.28$ and $\cos \alpha = 0.96$. The point A is at the top of the plane, the point C is at the bottom of the plane and the length of AC is 5 m. The part of the plane above the level of B is smooth and the part below the level of B is rough. A particle P is released from rest at A and reaches C with a speed of 2 m s^{-1} . The coefficient of friction between P and the part of the plane below B is 0.5. Find

(i) the acceleration of P while moving

(a) from A to B ,

(b) from B to C ,

[3]

(ii) the distance AB ,

[3]

(iii) the time taken for P to move from A to C .

[3]

7

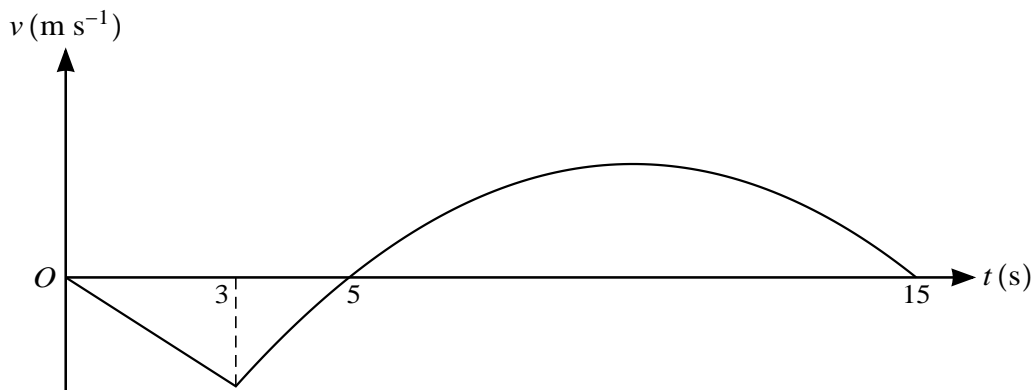

The diagram shows the velocity-time graph for the motion of a particle P which moves on a straight line BAC . It starts at A and travels to B taking 5 s. It then reverses direction and travels from B to C taking 10 s. For the first 3 s of P 's motion its acceleration is constant. For the remaining 12 s the velocity of P is $v \text{ m s}^{-1}$ at time $t \text{ s}$ after leaving A , where

$$v = -0.2t^2 + 4t - 15 \quad \text{for } 3 \leq t \leq 15.$$

(i) Find the value of v when $t = 3$ and the magnitude of the acceleration of P for the first 3 s of its motion. [3]

(ii) Find the maximum velocity of P while it is moving from B to C . [3]

(iii) Find the average speed of P ,

(a) while moving from A to B ,

(b) for the whole journey. [6]